



Single, Double & Triple Stack Bobbins

PRODUCT OVERVIEW:

Miles-Platts have hit a home run with their new single, double and triple stack bobbin for the E65/32/27 Core. Now you can stack in single, double or triple configurations and still use a standard bobbin.

Parts are in stock and available in multiple materials to meet your insulation system requirements.

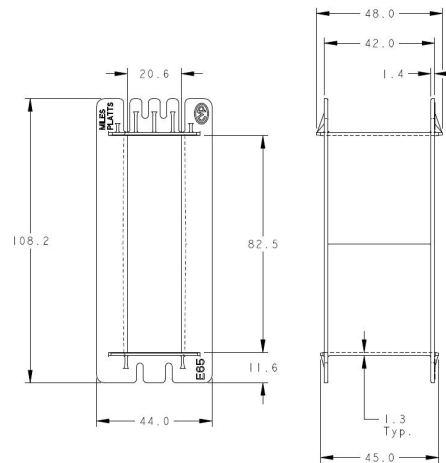
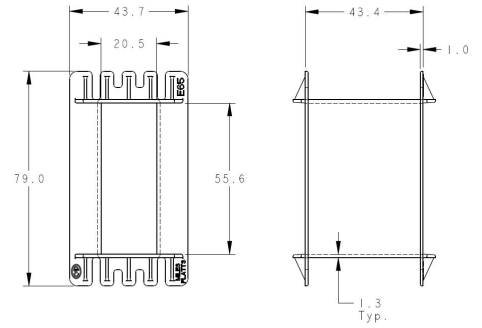
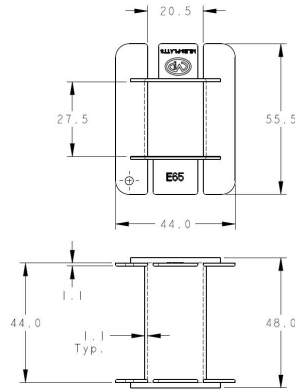

ABOUT DEXTER

Dexter Magnetic Technologies was founded as Permag Corporation in 1951 as the FIRST global magnetic materials distributor.

Since then, Dexter Magnetic Technologies has become your essential magnetic partner. The company's growing supply chain offers the most diverse offerings of current magnetic materials. Our experienced engineers and support staff can help you choose the correct "off-the-shelf" components, or assist in a custom, cost effective solution to your needs.

Part Number	Description	Stack Height	Material	Material Code
FE0360GNNBLK	E65/32/27 SS Without Pins	Single Height	25% Glass Reinforced Nylon to UL94V0	FGN NAT
FE0360FGNNAT	E65/32/27 SS Without Pins	Single Height	30% Glass Reinforced Nylon to UL94HB	GNN BLK
FE0370FGNNAT	E65/32/27 SS Without Pins	Double Height	25% Glass Reinforced Nylon to UL94V0	FGN NAT
FE0370GNNBLK	E65/32/27 SS Without Pins	Double Height	30% Glass Reinforced Nylon to UL94HB	GNN BLK
FE0380FGNNAT	E65/32/27 SS Without Pins	Triple Height	25% Glass Reinforced Nylon to UL94V0	FGN NAT
FE0380GNNBLK	E65/32/27 SS Without Pins	Triple Height	30% Glass Reinforced Nylon to UL94HB	GNN BLK

